



# Four-Rotor Hover Vehicle

www.solutions4u-asia.com

**GOOGOL TECHNOLOGY** The four-rotor hover vehicle consists of motors with airscrews, encoders, drive modules, motion controllers and slip rings, etc. It is a highly coupled multiple degrees of freedom system. Different flight controls such as elevation and depression, inclination and hovering of the vehicle can be achieved. The system is suitable for undergraduates, postgraduates and control theory researchers to carry out verification and research of control theory such as optimal control, robust control, etc.

The four-rotor hover vehicle is powered by the 4 airscrews of the motors placed at the gumball shaft. The front, left and right motors drive the corresponding airscrews to fulfill the elevation and depression of the vehicle, the left and right motors drive the corresponding airscrews to overturn the vehicle, while the rear motor drives the corresponding airscrews to realize the navigation of the vehicle. The 3 encoders which are installed on the platform detect the different aviation statuses of the vehicle and form a closed loop system, thus fulfill precise positioning of the elevation and depression, tilting and hovering of the vehicle. Slip rings are installed in the base of the vehicle so that the wirings will not tangle up when the vehicles rotate freely. It also helps to reduce friction.

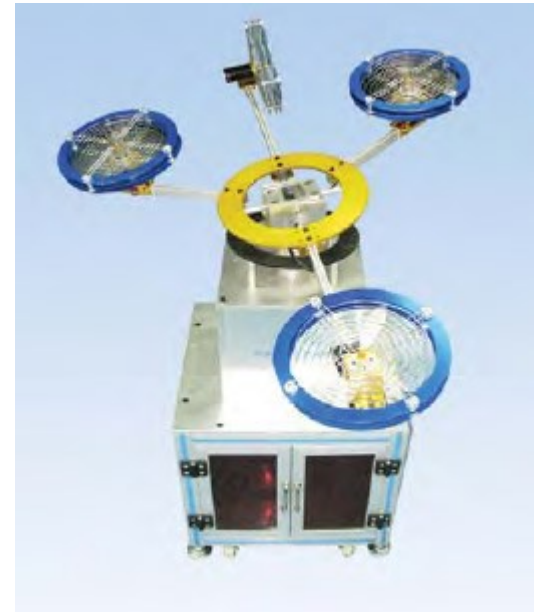

### Main Feature:

- Open architecture design
- Hardware platform based on PC and open architecture DSP motion controller
- Typical multi-input multi-output system (MIMO)
- Attractive appearance

### Reference experiments:

- System modeling and analysis experiment
- System open loop response analysis
- PID controller design

### Technical Specification

Size (L x W x H)	1000mm x 1000mm x 670mm
Pitch angle	-15° ~ 15°
Roll angle	-15° ~ 15°
Yaw angle	0~360°
Power input	AC220V, 50HZ, 2A
Weight	~50Kg
Motion controller	GT-400-SV-PCI
DC motor	24V 5000RPM
Pitch encoder	1000P/R
Roll encoder	1000P/R
Yaw encoder	600P/R
Slip ring	18 line

Distributed by:

**Solutions4U**

**Solutions 4U Sdn Bhd** (706527-A) 72-3C, Jalan Puteri 2/4, Bandar Puteri, 47100 Puchong, Selangor, Malaysia Tel : +603-8063 9300 Fax : +603-8063 9400  
**Solutions 4U Pte Ltd** (2007132962) 259 Onan Road, Singapore 424651 Tel: +65 6468 3325 Fax: +65 6764 5646 www.solutions4u-asia.com enquiry@solutions4u-asia.com

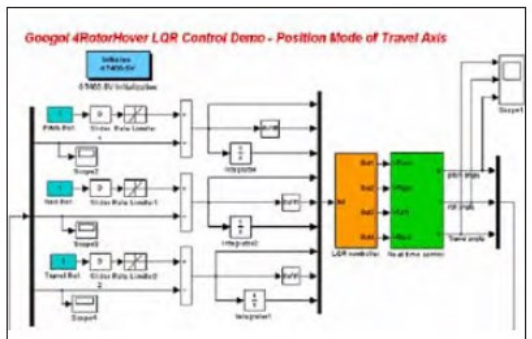

MATLAB Experiment Software

### System Modeling

$$\dot{X} = AX + Bu$$

$$Y = CX$$

$$\begin{bmatrix} \dot{p} \\ \dot{r} \\ \dot{y} \end{bmatrix} = A \begin{bmatrix} p \\ r \\ y \end{bmatrix} + B \begin{bmatrix} V_f \\ V_r \\ V_l \\ V_b \end{bmatrix}$$

p--Pitch r--Roll y--Yaw

System state space equation

### Ordering Guide

Model Number	Product Name	Description
GHP-3001	Four rotor hover vehicle	<ul style="list-style-type: none"> <li>• Four-rotor hover vehicle main body</li> <li>• GT-400-SV motion controller</li> <li>• Googol SIMULINK software experiment platform</li> </ul>